



ACS102-5Tx

ASD™ AC Switch Family

AC LINE SWITCH

PRELIMINARY DATASHEET

MAIN APPLICATIONS

- AC on-off static switching in appliance control systems
- Drive of low power high inductive or resistive loads like
 - relay, valve, solenoid, dispenser
 - pump, fan, micro-motor
 - low power lamp bulb, door lock

FEATURES

- Blocking voltage : $V_{DRM} / V_{RRM} = 500V$
- Clamping voltage : $V_{CL} = 600 V$
- Nominal current : $I_{T(RMS)} = 0.2 A$
- Gate triggering current : $I_{GT} < 5 mA$
- Switch integrated driver
- SO-8 package:
 - drive reference COM connected to 2 cooling pins
 - 3 mm creepage distance from pin OUT to other pins

BENEFITS

- Needs no more external protection snubber or varistor
- Enables equipment to meet IEC 1000-4-5 & IEC 335-1
- Reduces component count by up to 80 %
- Interfaces directly with a microcontroller
- Eliminates any stressing gate kick back on microcontroller
- Allows straightforward connection of several ACS on same cooling pad

DESCRIPTION

The ACS102 belongs to the AC line switch family built around the ASD concept. This high performance 5 mA switch circuit is able to control an up to 0.3 A load.

The ACS switch embeds a high voltage clamping structure to absorb the inductive turn off energy and a gate level shifter driver to separate the digital controller from the main switch. It is triggered with a negative gate current flowing out of the gate pin.

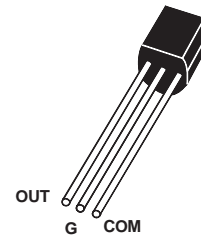

TO92
ACS102-5TA

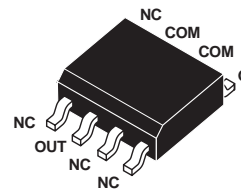

SO-8
ACS102-5T1

NC: Not Connected

FUNCTIONAL DIAGRAM

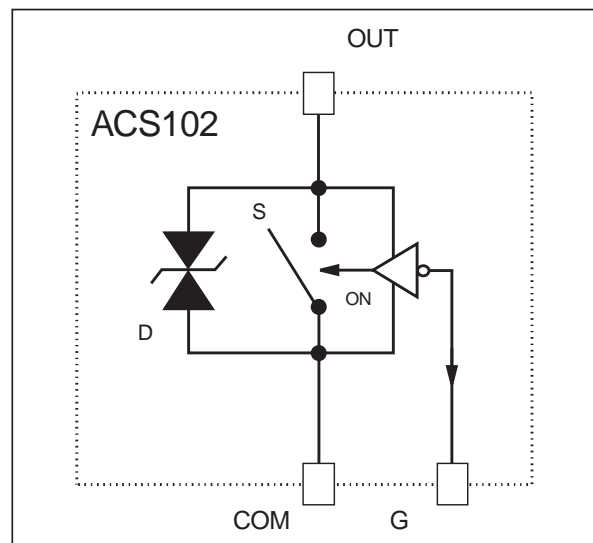

ACS102-5Tx

ABSOLUTE RATINGS (limiting values)

Symbol	Parameter		Value	Unit	
V_{DRM} / V_{RRM}	Repetitive peak off-state voltage		$T_j = 25\text{ }^\circ\text{C}$	500	V
$I_{T(RMS)}$	RMS on-state current full cycle sine wave 50 to 60 Hz	TO92	$T_{amb} = 75\text{ }^\circ\text{C}$	0.2	A
		SO-8	$T_{amb} = 75\text{ }^\circ\text{C}$	0.2	A
I_{TSM}	Non repetitive surge peak on-state current T_j initial = $25\text{ }^\circ\text{C}$, full cycle sine wave	F = 50 Hz		7.3	A
		F = 60 Hz		8	A
di/dt	Critical rate of rise of on-state current $I_G = 10\text{mA}$, $t_r = 100\text{ns}$	F = 120 Hz		20	A/ μs
V_{PP}	Non repetitive line peak pulse voltage	note 1		2	kV
T_{stg}	Storage temperature range			- 40 to + 150	$^\circ\text{C}$
T_j	Operating junction temperature range			0 to + 110	$^\circ\text{C}$
T_l	Maximum lead temperature for soldering during 10s			260	$^\circ\text{C}$

note 1 : according to test described by IEC 1000-4-5 standard & Figure 4.

SWITCH GATE CHARACTERISTICS (maximum values)

Symbol	Parameter	Value	Unit
$P_{G(AV)}$	Average gate power dissipation	0.1	W
I_{GM}	Peak gate current ($t_p = 20\mu\text{s}$)	1	A
V_{GM}	Peak positive gate voltage (respect to the pin COM)	5	V

THERMAL RESISTANCES

Symbol	Parameter	Value	Unit	
$R_{th(j-a)}$	Junction to ambient	TO92	150	$^\circ\text{C/W}$
		SO-8	150	$^\circ\text{C/W}$
$R_{th(j-l)}$	Junction to leads for full AC line cycle conduction	TO92	60	$^\circ\text{C/W}$

ELECTRICAL CHARACTERISTICS

For either positive or negative polarity of pin OUT voltage respect to pin COM voltage

Symbol	Test Conditions	Values	Unit	
I_{GT}	$V_{OUT}=12\text{V}$ (DC) $R_L=140\Omega$	$T_j=25\text{ }^\circ\text{C}$ MAX	5	mA
V_{GT}	$V_{OUT}=12\text{V}$ (DC) $R_L=140\Omega$	$T_j=25\text{ }^\circ\text{C}$ MAX	0.9	V
V_{GD}	$V_{OUT}=V_{DRM}$ $R_L=3.3\text{k}\Omega$	$T_j=110\text{ }^\circ\text{C}$ MIN	0.2	V
I_H	$I_{OUT}=100\text{mA}$ gate open	$T_j=25\text{ }^\circ\text{C}$ TYP	20	mA
		MAX	tbd	
I_L	$I_G=20\text{mA}$	$T_j=25\text{ }^\circ\text{C}$ TYP	25	mA
		MAX	tbd	
V_{TM}	$I_{OUT}=0.3\text{A}$ $t_p=380\mu\text{s}$	$T_j=25\text{ }^\circ\text{C}$ MAX	1.2	V
I_{DRM} I_{RRM}	$V_{OUT}=V_{DRM}$ $V_{OUT}=V_{RRM}$	$T_j=25\text{ }^\circ\text{C}$ MAX	2	μA
		$T_j=110\text{ }^\circ\text{C}$ MAX	50	
dV/dt	$V_{OUT}=400\text{V}$ gate open	$T_j=110\text{ }^\circ\text{C}$ MIN	300	V/ μs
$(di/dt)_c$	Turn off = 10ms, $(dV/dt)_c = 5\text{V}/\mu\text{s}$	$T_j=110\text{ }^\circ\text{C}$ MIN	0.1	A/ms
	Turn off = 20ms, $(dV/dt)_c = 10\text{V}/\mu\text{s}$		0.15	
V_{CL}	$I_{CL}=1\text{mA}$ $t_p=1\text{ms}$	$T_j=25\text{ }^\circ\text{C}$ TYP	600	V

tbd = to be defined

PARAMETER DESCRIPTION

Parameter Symbol	Parameter Description
I_{GT}	Gate triggering current
V_{GT}	Gate triggering voltage
V_{GD}	Non triggering voltage
I_H	Holding current
I_L	Latching current
V_{TM}	On state voltage
I_{DRM} / I_{RRM}	Forward or reverse leakage current
dV/dt	Static pin OUT voltage rise
$(di/dt)_c$	Turn off current rate of decay
V_{CL}	Clamping voltage

AC LINE SWITCH BASIC APPLICATION

The ACS102 device is well adapted to washing machine, dish washer, tumble drier, refrigerator, water heaters, and cookware. It has been designed especially to switch on & off low power loads such as solenoid, valve, relay, dispenser, micro-motor, pump, fan, door lock, and low wattage lamps bulbs.

Pin COM : Common drive reference to connect to the power line neutral

Pin G : Switch Gate input to connect to the digital controller through a resistor

Pin OUT : Switch Output to connect to the load

This ACS switch is triggered with a negative gate current flowing out of the gate pin G. It can be driven directly by the digital controller through a resistor as shown on the typical application diagram. No protection device (zener or capacitor) are required between gate and COM terminals.

The SO-8 version allows to connect several ACS102 devices on the same cooling PCB pad which is the COM pin.

In appliances systems, the ACS102 switch intends to drive low power load in full cycle ON / OFF mode. The turn off commutation characteristics of these loads are described in table 1.

Thanks to its thermal and turn off commutation performances, the ACS102 switch is able to drive with no turn off aid snubber a load up to 0.2 A (door lock, lamp, relay, valve & micro motor) when this load has to switch off within one half AC line cycle, and up to 0.3 A (pump, fan) when this load can switch off within one full AC line cycle.

Table 1: Low power load turn off commutation requirement (230V AC applications).

LOAD	IRMS (A)	POWER FACTOR	$(di/dt)_c$ (A/ms)	$(dV/dt)_c$ (V/ μ s)	TURN-OFF DELAY (ms)
Door lock, lamp	< 0.2	1	< 0.1	< 0.15	< 10
Relay Valve Dispenser Micro-motor	< 0.2	> 0.7	< 0.1	< 5	< 10
Pump Fan	< 0.3	> 0.2	< 0.15	< 10	< 20

TYPICAL APPLICATION DIAGRAM

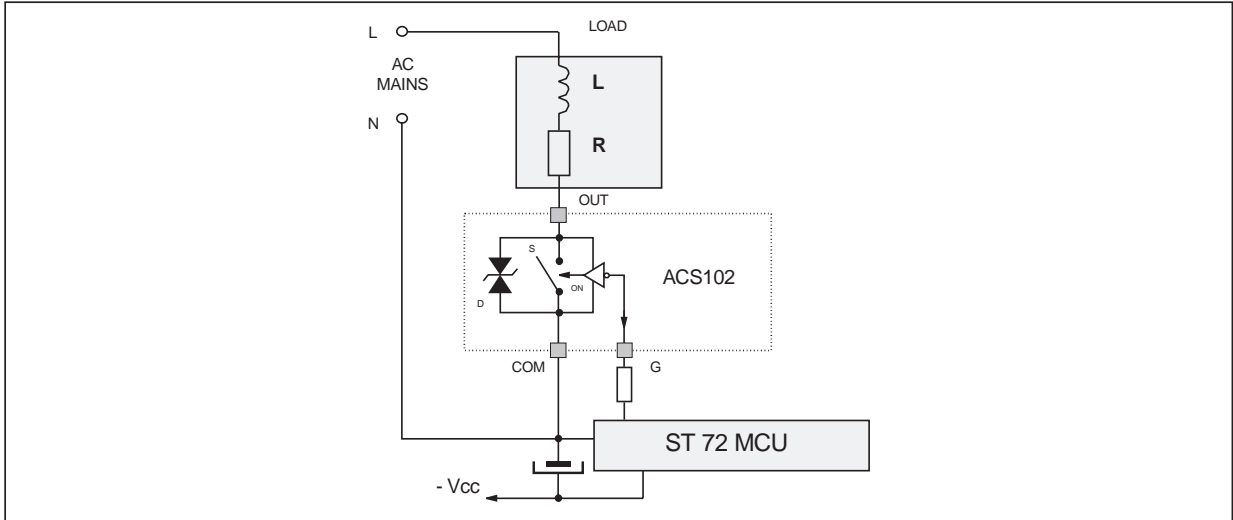

HIGH INDUCTIVE SWITCH-OFF OPERATION

At the end of the last conduction half-cycle, the load current reaches the holding current level I_H , and the ACS™ switch turns off. Because of the inductance L of the load, the current flows through the avalanche diode D and decreases linearly to zero. During this time, the voltage across the switch is limited to the clamping voltage V_{CL} .

The energy stored in the inductance of the load depends on the holding current I_H and the inductance (up to 10 H); it can reach about 20 mJ and is dissipated in the clamping diode section. The ACS switch sustains the turn off energy, because its clamping section is designed for that purpose.

Fig 1: Turn-off operation of the ACS102 switch with an electro valve: waveform of the gate current I_G , pin OUT current I_{OUT} & voltage V_{OUT} .

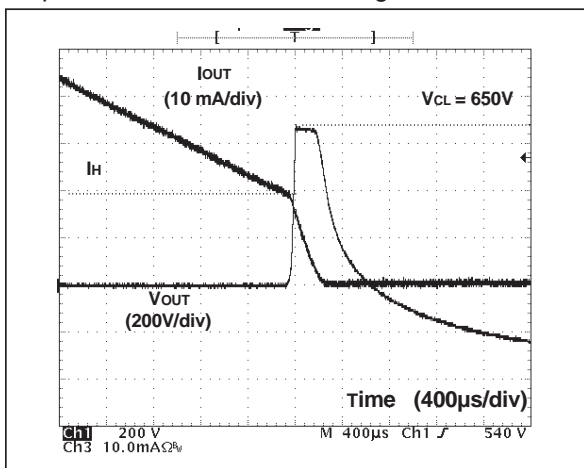
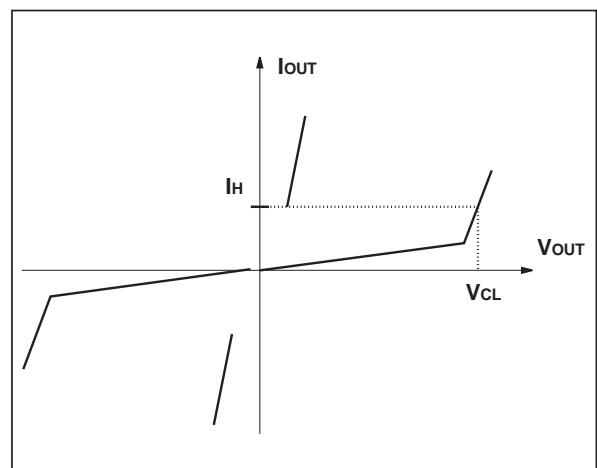

Fig 2: ACS102 switch static characteristic.



AC LINE TRANSIENT VOLTAGE RUGGEDNESS

The ACS102 switch is able to sustain safely the AC line transient voltages either by clamping the low energy spikes or by breaking over under high energy shocks, even with high turn-on current rates of increase.

The test circuit of the figure 3 is representative of the final ACS application and is also used to stress the ACS switch according to the IEC1000-4-5 standard conditions. Thanks to the load, the ACS switch sustains the voltage spikes up to 2 kV above the peak line voltage. It will breaks over safely even on resistive load where the turn on current rate of increase is high as shown on figure 4. Such non repetitive test can be done 10 times on each AC line voltage polarity.

Fig. 3: Overvoltage ruggedness test circuit for resistive and inductive loads according to IEC 1000-4-5 standard.
 $R = 150\Omega$, $L = 5\mu H$, $V_{PP} = 2kV$.

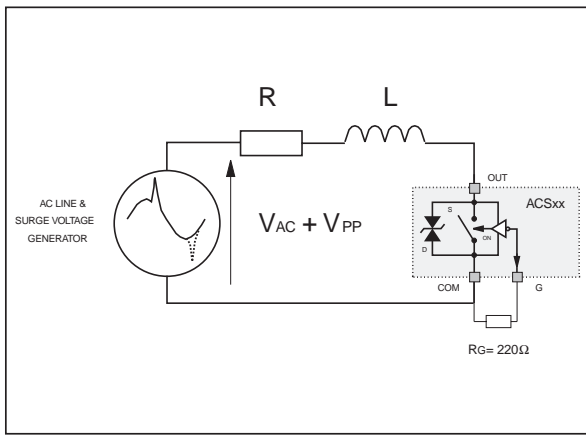

Fig. 4: Current and Voltage of the ACS during IEC 1000-4-5 standard test with $R = 150\Omega$, $L = 5\mu H$ & $V_{PP} = 2kV$.

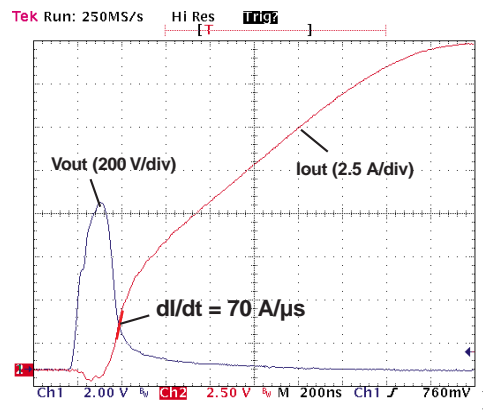

Fig 5: Relative variation of gate trigger current versus junction temperature

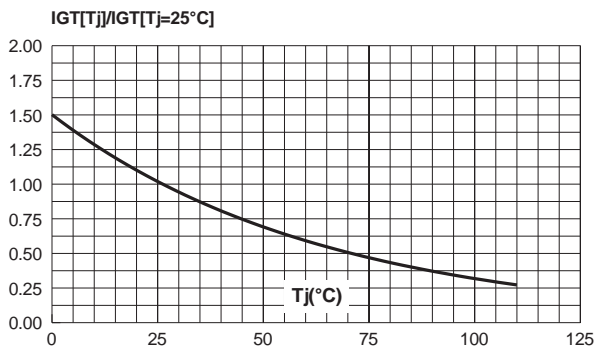
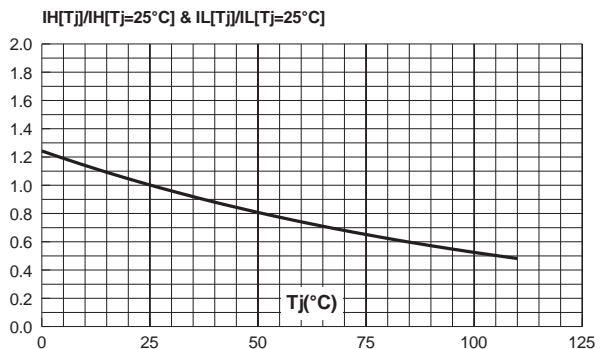

Fig 6: Relative variation of holding & latching currents versus junction temperature



ACS102-5Tx

Fig 7: Typical on state characteristics @ Tj max
 $V_{TO} = 0.85\text{ V}$ & $R_T = 0.40\ \Omega$ (maximum values)
 $P_{on} = V_{TO} \cdot 2 \cdot \sqrt{2} \cdot I_{T(RMS)} / \Pi + R_T \times I_{T(RMS)}^2$

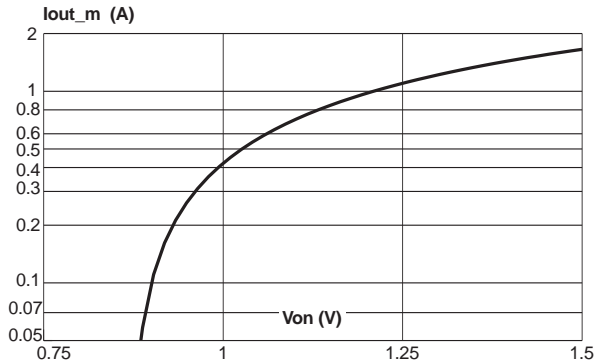

Fig 8: Maximum RMS switch current versus ambient temperature on inductive load (PF>0.1) and a low repetitive rate (F < 0.1 Hz) for both TO92 and SO8.

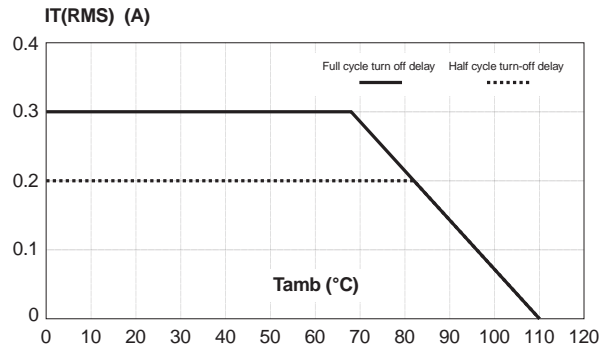

Fig. 9-1: Relative variation of the junction to ambient thermal impedance versus conducting pulse duration for the SO8. Standard foot print with 35µm copper layout thickness.

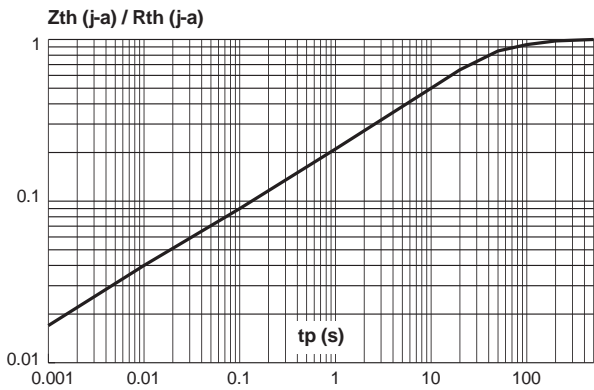
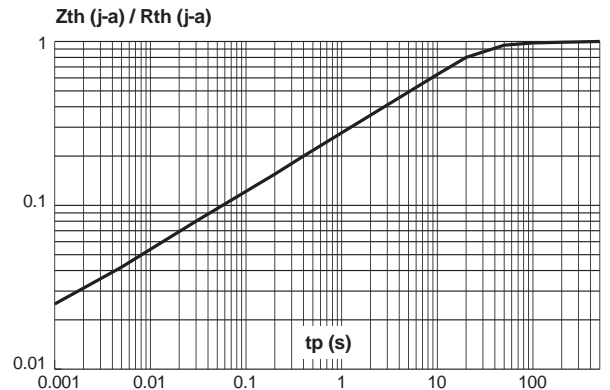
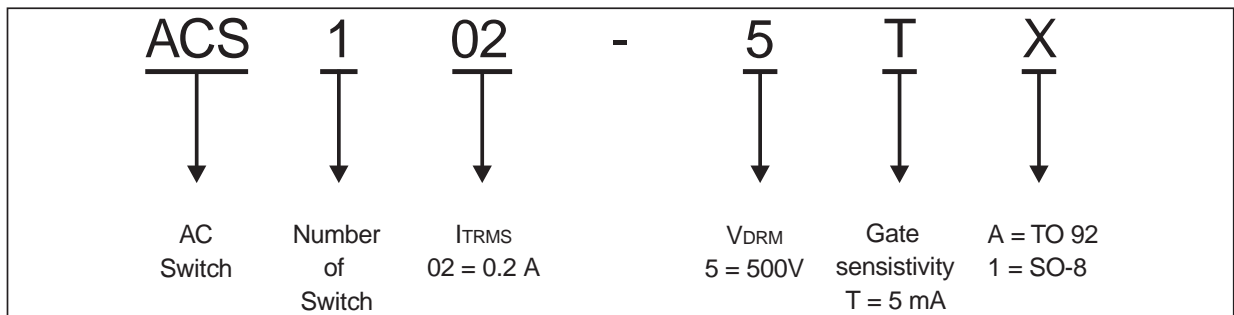

Fig. 9-2: Relative variation of the junction to ambient thermal impedance versus conducting pulse duration for the TO92.



ORDERING INFORMATION



PACKAGE OUTLINE MECHANICAL DATA
SO-8

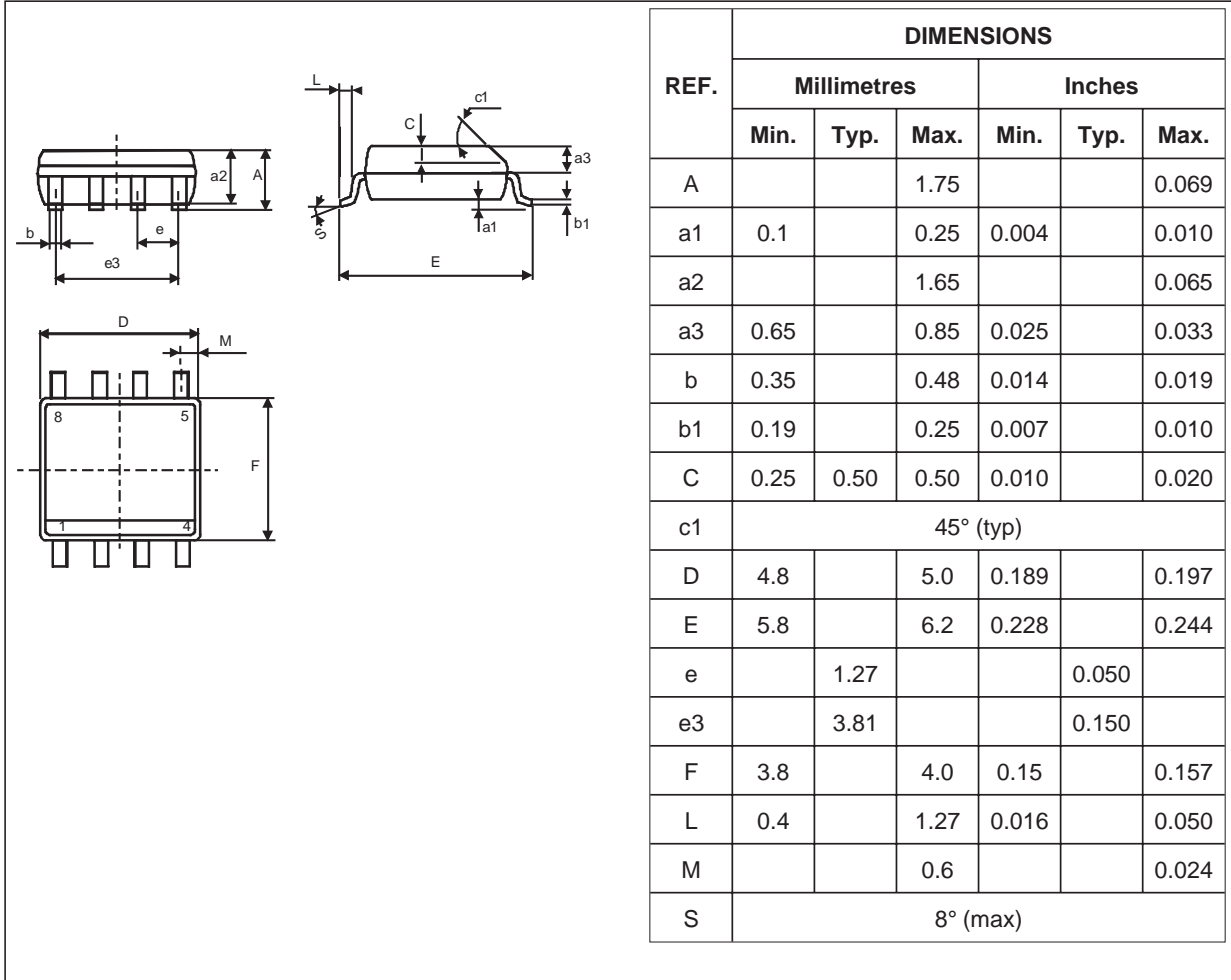

PACKAGE FOOT PRINT
SO-8

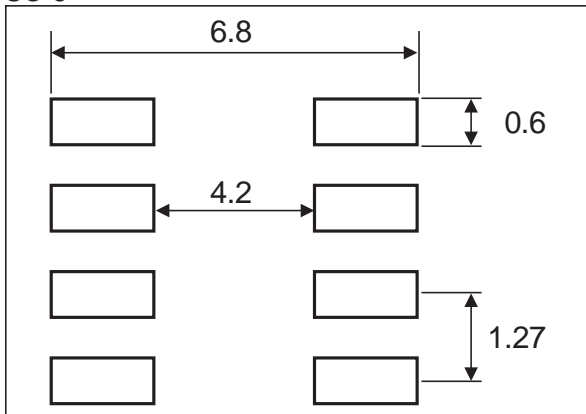

ACS102-5Tx

PACKAGE OUTLINE MECHANICAL DATA

TO92 Plastic

REF.	DIMENSIONS					
	Millimeters			Inches		
	Min.	Typ.	Max.	Min.	Typ.	Max.
A		1.35			0.053	
B			4.70			0.185
C		2.54			0.100	
D	4.40			0.173		
E	12.70			0.500		
F			3.70			0.146
a			0.45			0.017

Ordering type	Marking	Package	Weight	Base qty	Delivery mode
ACS102-5TA	ACS102	TO92	0.2g	2500	Bulk
ACS102-5TA-TR	ACS102	TO92	0.2g	2000	Tape & reel
ACS102-5T1-TR	ACS102	SO-8	0.11g	2500	Tape & reel

TM: ASD and ACS are trademarks of STMicroelectronics .

Information furnished is believed to be accurate and reliable. However, STMicroelectronics assumes no responsibility for the consequences of use of such information nor for any infringement of patents or other rights of third parties which may result from its use. No license is granted by implication or otherwise under any patent or patent rights of STMicroelectronics. Specifications mentioned in this publication are subject to change without notice. This publication supersedes and replaces all information previously supplied. STMicroelectronics products are not authorized for use as critical components in life support devices or systems without express written approval of STMicroelectronics.

The ST logo is a registered trademark of STMicroelectronics

© 1999 STMicroelectronics - Printed in Italy - All rights reserved.

STMicroelectronics GROUP OF COMPANIES

Australia - Brazil - China - Finland - France - Germany - Hong Kong - India - Italy - Japan - Malaysia
Malta - Morocco - Singapore - Spain - Sweden - Switzerland - United Kingdom - U.S.A.

<http://www.st.com>